

## Technical Specifications – WPOZ 0150

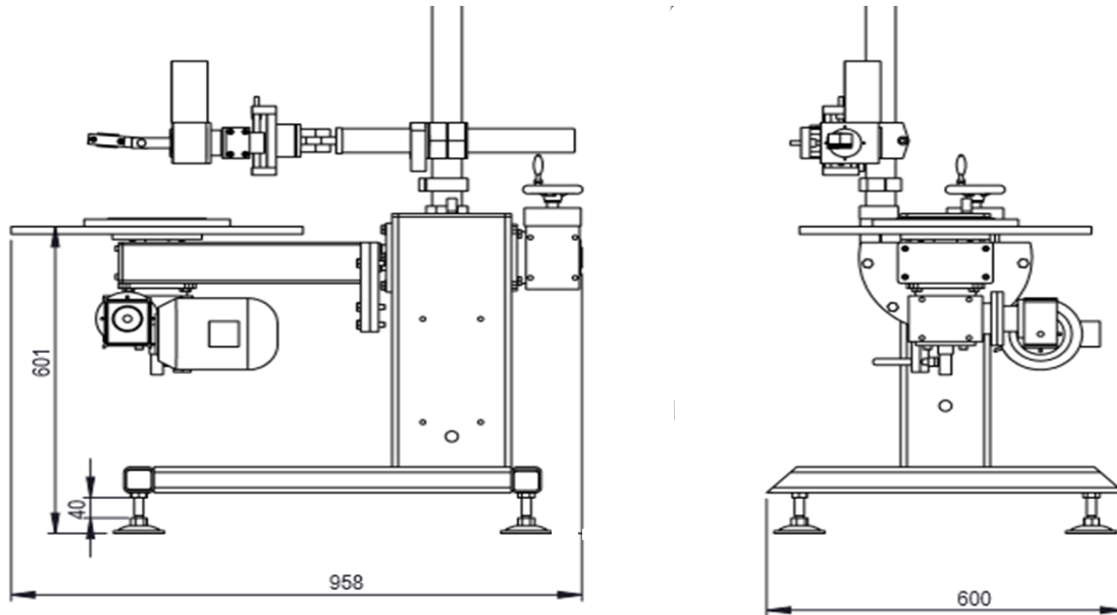

|                             |   |
|-----------------------------|---|
| Max. Load (N)               | 1500  |
| Axis Eccentricity           | 150 mm for Rotation and Tilting                           |
| Rotation Speed (rpm/min)    | Min 0,4 – Max 4 at 5 Hz – 50 Hz Range                     |
| Rotation Torque (kg.m)      | 22,5 kgm  |
| Rotation Motor              | 1 x .. Kw AC Motor  |
| Tilting Angle               | 120°  |
| Tilting Speed from 0 to 120 | 30 second   |
| Tilting Torque (kg.m)       |   |
| Tilting Motor               | No, Gear Box with Handwheel                               |
| Driver                      | 1 x .. Kw   |
| Face Plate Diameter         | 400 mm, middle holl; Ø130mm, t;18mm                       |
| Fixing Slots                | M10 Holes   |
| Control Device              | Hand Pendant (3m cable)                                   |
| Incoming Supply             | 380/400V, 3Ph, 50Hz @ 5 – 50 Hz                           |
| Applicable Optional         | Foot Pedal  |
| Colour                      | RAL5018 – TURQUOISE RAL9005 – BLACK /<br>Texture Painting |
| Welding Torch Holder        | Yes   |
| Shipping Dimension & Weight | Width 600mm x Length 960mm x Height 600mm<br>/ 175 Kg     |

Westermans International Ltd  
Unit 4, Midland Distribution Centre, Markfield Road  
Groby  
Leicester  
LE6 0FS, UK